

Freedom 360° Series

Pressurized Models With Mix Transfer System

Model 44RMT & 15RMT

At only 18" wide, these single head soft serve machines are excellent for featuring soft serve parfaits, splits, sundaes or cones. They also dispense a quality soft serve ice cream, frozen yogurt, or custard. Model 15RMT is 6 inches deeper and has a larger freezing cylinder and dispensing capacity than the 44RMT.

Model 30RMT

This high volume unit is designed to meet the product capacity and quality demands of the successful soft serve operation. At a width of just 26", it also dispenses a quality soft serve ice cream, frozen yogurt, or custard.

Special Features

Mix Transfer System*

Exclusively from Electro Freeze, the revolutionary mix transfer system...it's so simple it takes only minutes to clean. Reap all the benefits of a pressurized system with the cleaning time of a gravity fed freezer.

Refrigerant

Friendly to the environment, these models use R404A refrigerant.

Refrigerated Mix Cabinet

Located in the lower portion of the freezer, the refrigerated mix cabinet provides easy access for filling mix reservoirs. Simply place the mix carton into the cabinet or fill the mix containers, insert the mix tube from each mix transfer system and that's it --- you're ready to make product.

Night Switch

The night switches enable you to close shop at the end of a business day and leave all mix in the freezer (cabinet and cylinders) under refrigeration, so you're ready for operation the next day.

Dispensing Head

Using the finest insulating material, prevents frost and drips. Easy pull down handle with adjustable dispensing speed.

Beater Blades

Plastic, durable and long wearing.

Mix Level Indicator

The mix level indicator features a flashing light to alert the operator when mix is needed.



Model 44RMT
15RMT



Model 30RMT

* U.S. Patent #5,349,825

ELECTRO FREEZE®

Plumbing & Electrical Connections

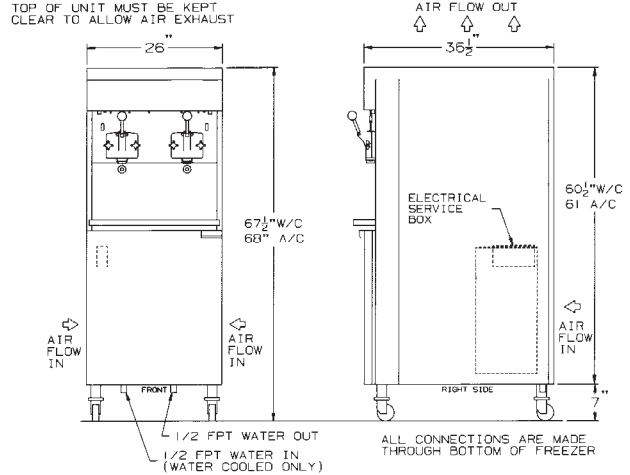
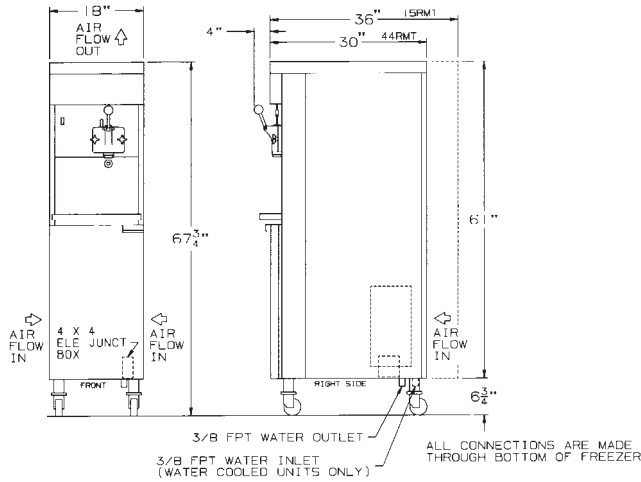

Model 44RMT & 15RMT

Model 30RMT

SPECIFICATIONS

All specifications subject to change without notice. Check nameplate for exact electrical data.

MODEL NO.	MOTOR H.P.		DIMENSIONS			NET WT.	TOTAL AMPS				
	Beater	Compressor	D.	W.	H.		1 Phase Water	1 Phase Air	3 Phase Water	3 Phase Air	
44RMT	2 HP	6300 BTU	30"	18"	68"	510 LB.	18.0	19.4	13.9	15.3	
		1.5 HP	76 CM	46 CM	173 CM	232 KG					
15RMT	2 HP	8800 BTU	36"	18"	68"	530 LB.	22.5	24.7	16.9	19.1	
		2 HP	91 CM	46 CM	173 CM	241 KG					
30RMT	TWO	8800 BTU	36 1/2"	26"	67 1/2"	850 LB.	LT 22.5	LT 24.7	LT 16.9	LT 19.3	
	2 HP	TWO 2.0 HP	93 CM	66 CM	171 CM	386 KG	RT 22.3	RT 24.5	RT 16.7	RT 19.1	
							MAX FUSE SIZE/HACR CIRCUIT BREAKER				
							44RMT	25.0 A.	25.0 A.	20.0 A.	20.0 A.
							15RMT	35.0 A.	35.0 A.	25.0 A.	30.0 A.
							30RMT	35.0 A.	35.0 A.	25.0 A.	30.0 A.

Refrigerant: 404a

Air or water cooled self contained.

Standard wiring—230 volts A.C., 60 HZ, Single Phase—2 wire

208/230 volts A.C., 60 HZ, Three Phase—3 wire

Electrical characteristics other than above available on request from Sales Office.

Authorized Distributor

division of H.C. DUKE & SON, INC.

2116 - 8th Avenue • East Moline, Illinois 61244

Phone (309) 755-4553 • (800)755-4545

Fax (309) 755-9858

E-mail: sales@electrofreeze.com • www.electrofreeze.com

Certified and/or listed by:



*UL listed and listed by Underwriters Laboratories under Canadian National Standard C22.2 No. 120-M91

**Select Voltages @ 50 HZ